

Drawer Slide Assembly

Determine the quantity of each size drawer.
 Starting with the location of the bottom drawer, attach the drawer slide to the vertical in the first hole above the cam-drilled shelf with 10.5mm Euro Screws (# 25.3610).
 Determine the height of the drawer and count the number of holes using the chart listed below to find the placement of the next slide. Repeat for additional drawers. Using the chart, subtract one hole from the top drawer and install the cam-drilled shelf.
 See **DIAGRAM 8A & 8B.**

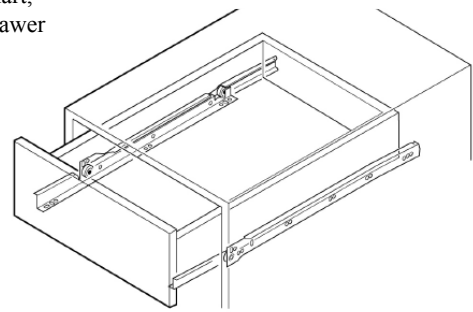

DIAGRAM 8A

<u>EXPOSED HOLES BETWEEN SLIDES</u>	<u>DRAWER BOX HEIGHT</u>
3 holes	5" height
5 holes	8" height
8 holes	12" height

Cam shelf location

5" Drawer spacing

8" Drawer spacing

Bottom drawer slide

DIAGRAM 8B

